

## AMS MCL Automatic Barrier

The AMS MCL barrier is made for very intensive use and for clear openings of up to 8 metres.  
They are ideal for any context

### Features

- Between 4 and 8 second opening time – depending on barrier length
- MERAK BM control unit
- Electronic limit switch
- Mechanical locking
- Key Switch release
- Purpose built for intensive use frequency
- IP54 rated
- Can operate in temperatures as low as -20°C and up to 50°C

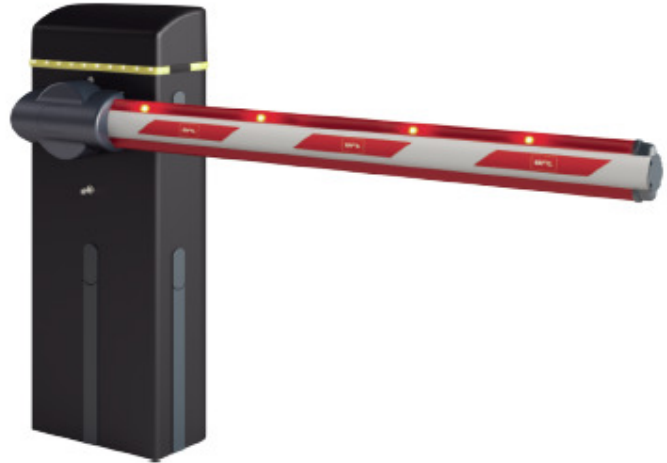

### Details

With the newly released MERAK BM control board featuring programming display and a built in two channel radio receiver, the AMS MCL automatic barrier is cutting edge technology in its field. All these features are mounted in the upper part of the barrier for an easier and more convenient access.

IP54 rated, meaning that the enclosure has a high level of protection against particles and a fair amount of protection against water. Also, features a limit switch system with electronic adjustment which speeds up installation and ensures maximum precision in movement.

Using 24v technology to ensure optimum performance with a precise adjustment of slowdown in closing and opening. With safety being our key aspect, we ensure that the immediate stopping and reversal of movement in the presence of obstacles, is active. The efficiency of the technology is a guarantee of the products reliability.

**Technical Specification**

<b>Control Unit</b>	MERAK BM
<b>Motor Power Supply</b>	24 v
<b>Power Input</b>	300 w
<b>Type of Limit Switch</b>	Electronic
<b>Slowdown</b>	Yes
<b>Locking</b>	Mechanical
<b>Release</b>	Key
<b>Impact Reaction</b>	Encoder

DIMENSION (MM)

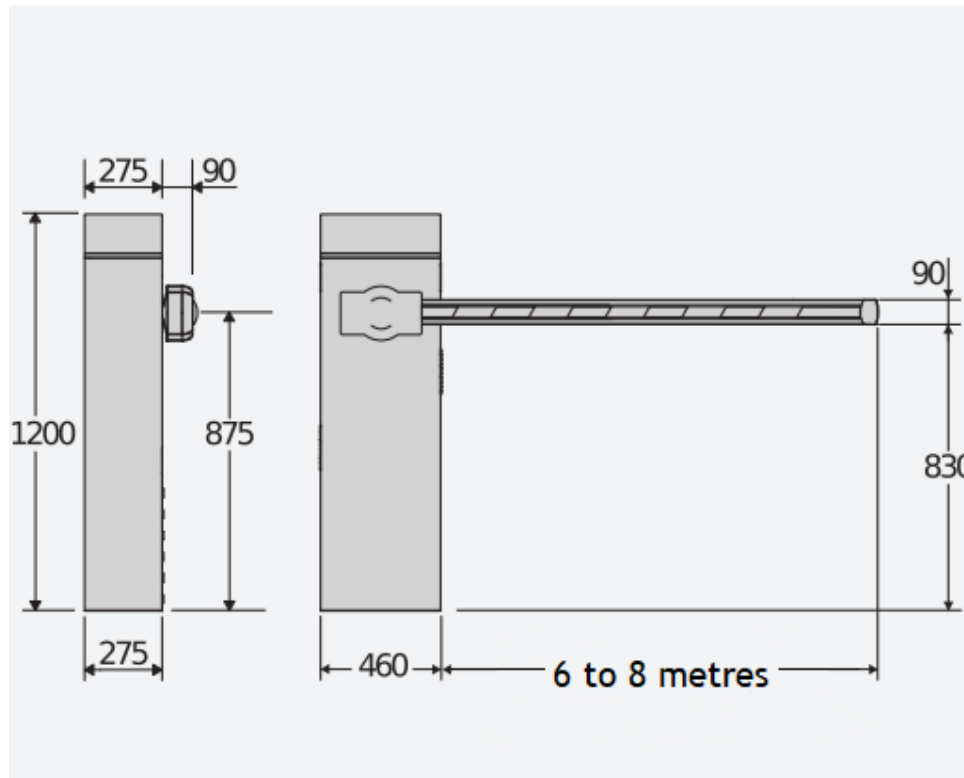

For more information about our AMS MCL Automatic Barriers, please contact us on:

01254 234248 or [sales@automatesystems.co.uk](mailto:sales@automatesystems.co.uk)

